

PARTS LIST			
ITEM	QTY	PART NUMBER	DESCRIPTION
1	1	02 000 008	LINESTAKE, 3/8" VINYL
2	4	02 000 228	WASHER, 1/4 EXT TOOTH SS
3	16	02 000 230	GROMMET, PANEL INSERT NYLON
4	4	02 000 271	U-NUT, 1/4-20 MULTI-THREAD
5	4	02 000 380	BOLT, 1/4-20 x 3/4 SS
6	4	02 000 381	WASHER, 1/4 FLAT SS
7	8	02 000 398	SCREW, 14 x 3/4 SLT HEX WSHR SS
8	8	02 000 534	SCREW, 10-24 x 1/2 PHIL PAN TYP
9	21	02 000 543	SCREW, 10 x 1/2 HEX WSHR TEK SS
10	1	03 000 217	COIL, CONDENSER 106G
11	2	06 000 319	BRKT, MTG 106 UNIT
12	1	06 000 323	BRACE, CASE TOP 106
13	1	06 001 575	HOUSING, FAN 106G
14	2	06 001 576	PLATE, BAFFLE 106G
15	1	06 001 577	HOUSING, BOTTOM 106G
16	2	11 000 147	FAN, 11" PULLER 12V

MOUT INFO

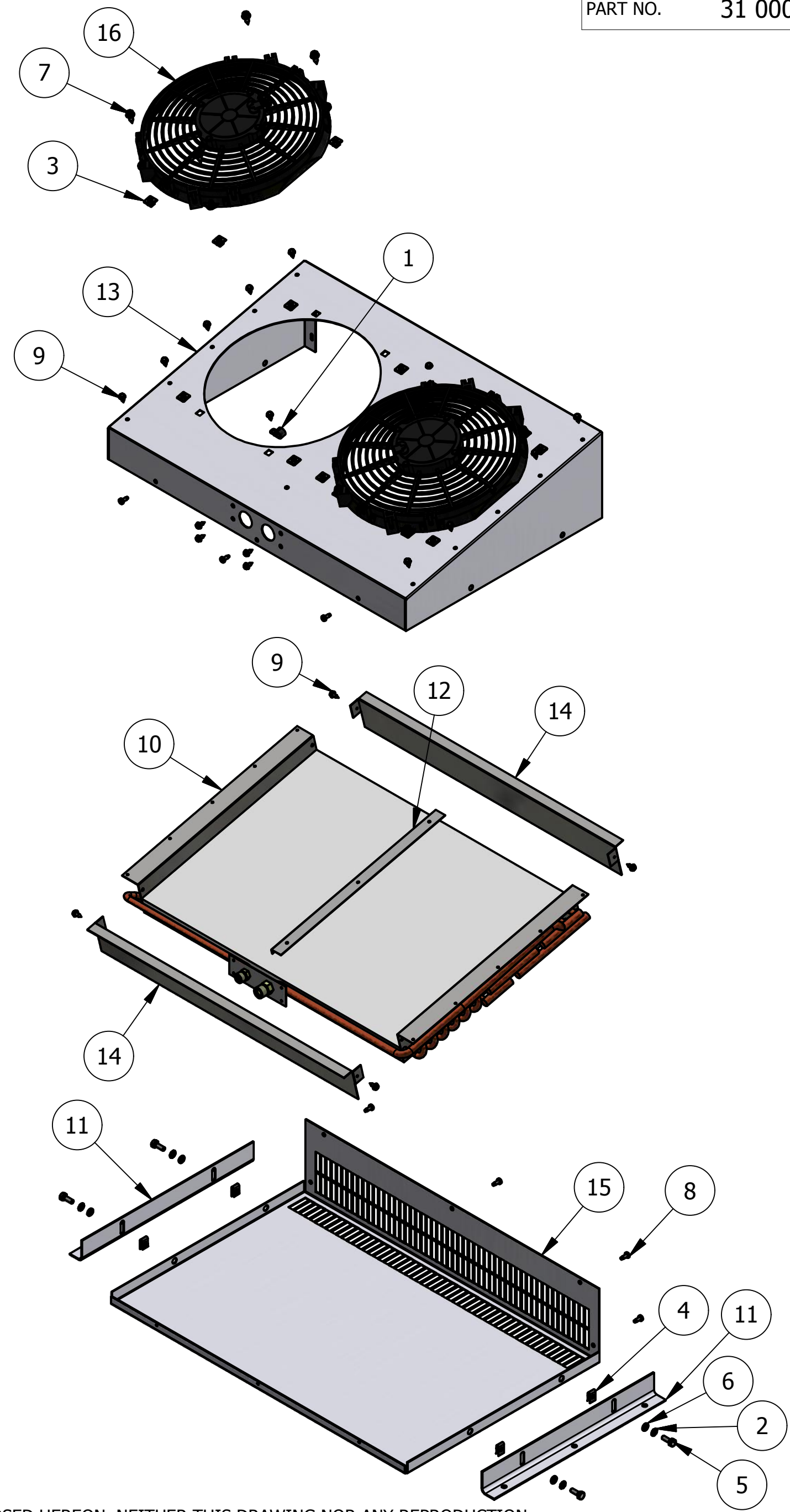
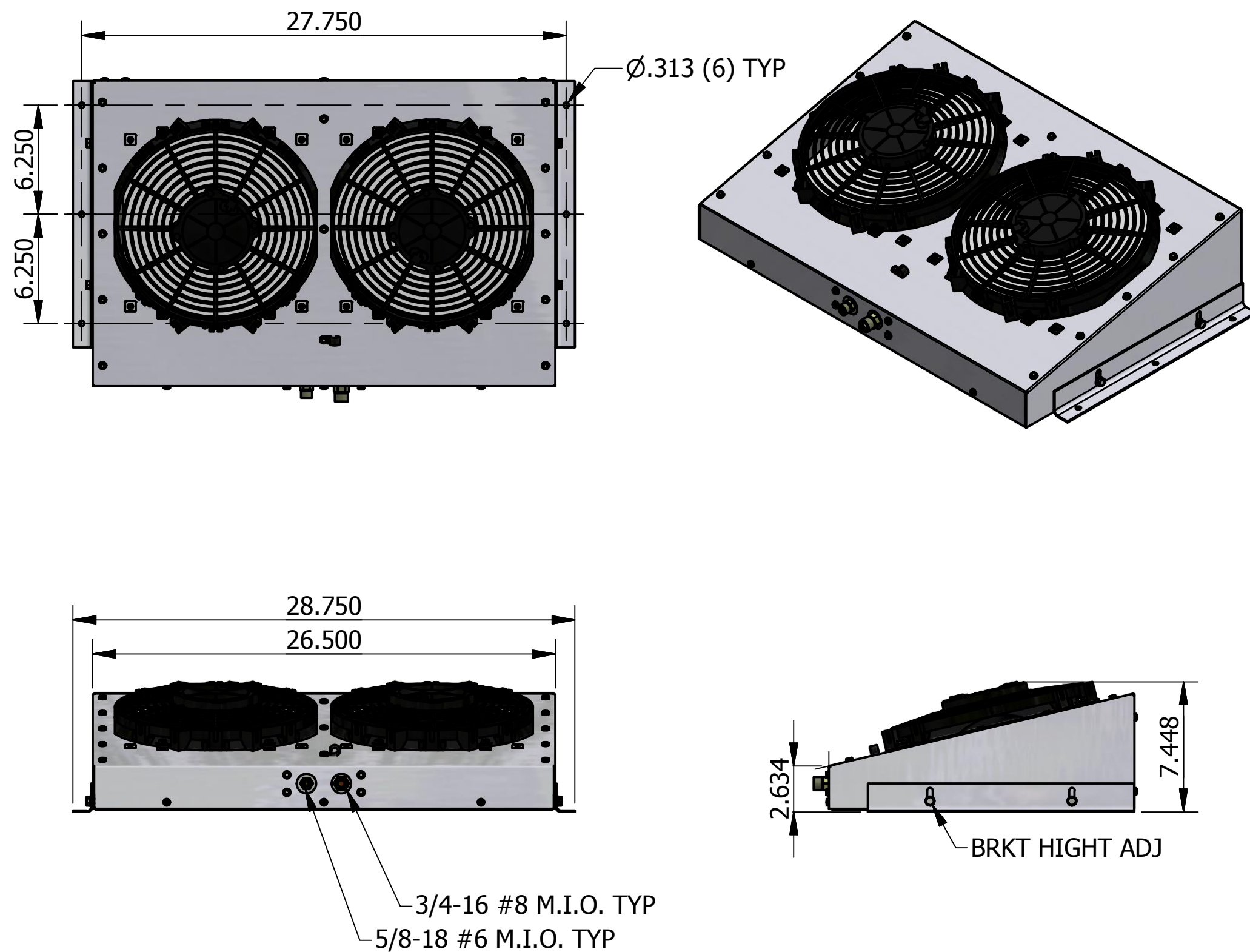

PROPRIETARY & CONFIDENTIAL. UNPUBLISHED WORK COPYRIGHT PRO AIR LLC. PRO AIR, LLC CLAIMS PROPRIETARY RIGHTS IN THE MATERIAL DISCLOSED HEREON. NEITHER THIS DRAWING NOR ANY REPRODUCTION OR PORTION THEREOF MAY BE DISTRIBUTED OR USED TO MANUFACTURE ANYTHING SHOWN HEREON WITHOUT PERMISSION IN WRITING FROM PROAIR, LLC.

REV. A

A		18-090		RELEASED TO PRODUCTION		CEB		4/10/18		 2900 COUNTY RD 6 W ELKHART, IN 46514		TITLE:		PART NO. 31 000 092	
LET.	NO.	REVISION		BY	DATE	SIGNATURES		DATE				FRIGIKING, 106G CONDENSER		SCALE: .15 : 1	SIZE A
						DRAWN CEB		4/10/18				USAGE: ALL		SHEET 1 OF 1	
						CHECKED RAI		4/10/18							
						APPROVED									