

| PARTS LIST |     |             |                                  |
|------------|-----|-------------|----------------------------------|
| ITEM       | QTY | PART NUMBER | DESCRIPTION                      |
| 1          | 4   | 02 000 157  | NUT, 8-32 NYLON LOCK             |
| 2          | 10  | 02 000 597  | SCREW, 10-24 x 5/8 BLK TYPE 23 T |
| 3          | 4   | 02 000 721  | BOLT, 8-32 x 3.25 PHIL ZINC      |
| 4          | 1   | 03 000 020  | COIL, HEATER 420                 |
| 5          | 1   | 06 000 176  | CASE, COIL MOUNTING 420          |
| 6          | 2   | 06 000 178  | BRKT, MTG 420                    |
| 7          | 1   | 06 001 843  | PANEL, MOTOR MOUNTING            |
| 8          | 1   | 11 000 213  | GRILLE, 120mm X 120mm            |
| 9          | 1   | 11 000 271  | FAN, 120mm 3 SPEED 12 VOLT       |
| 10         | 1   | 15 000 028  | FAN, 120mm 12 VOLT               |

**MOUNT INFO**

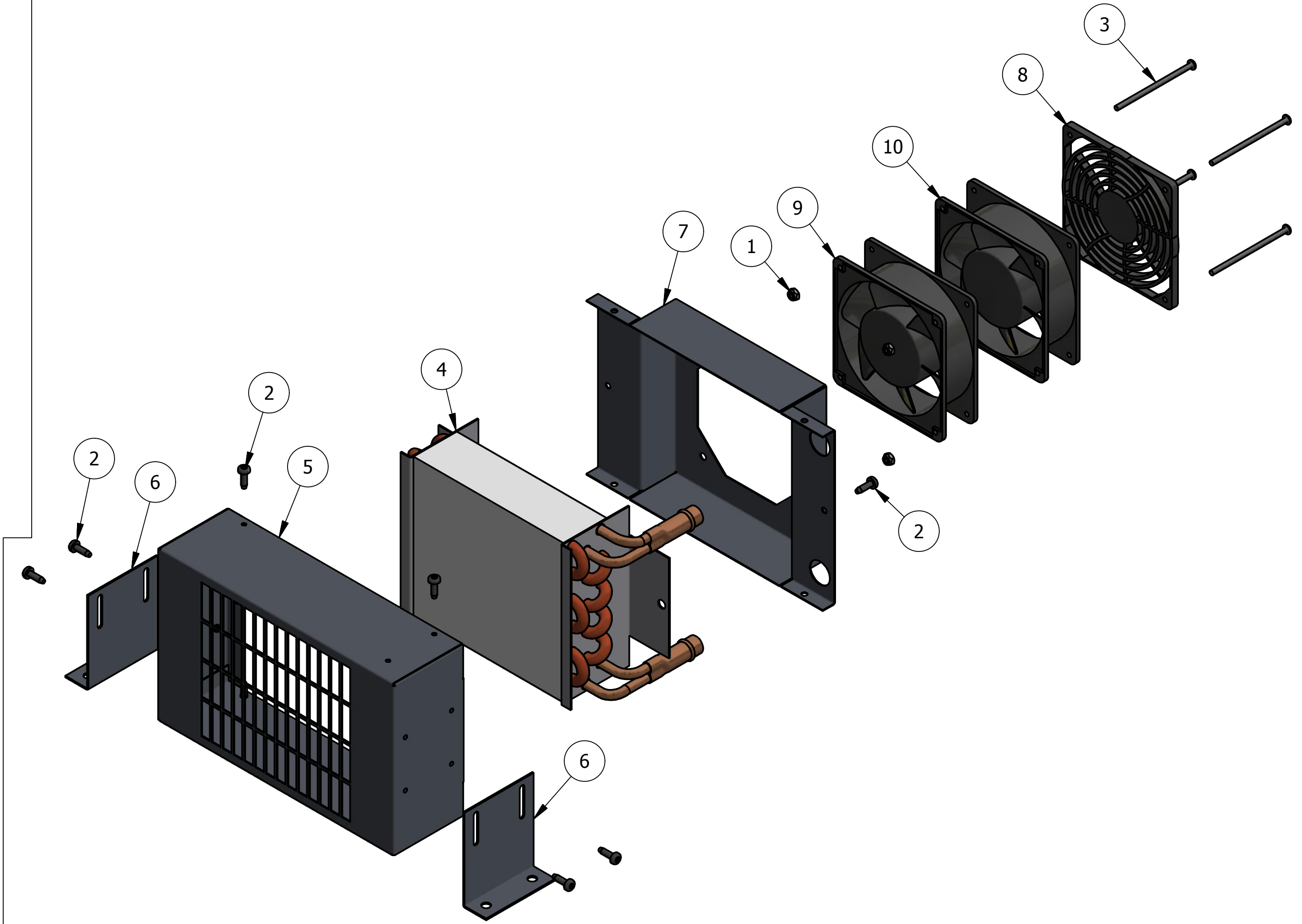
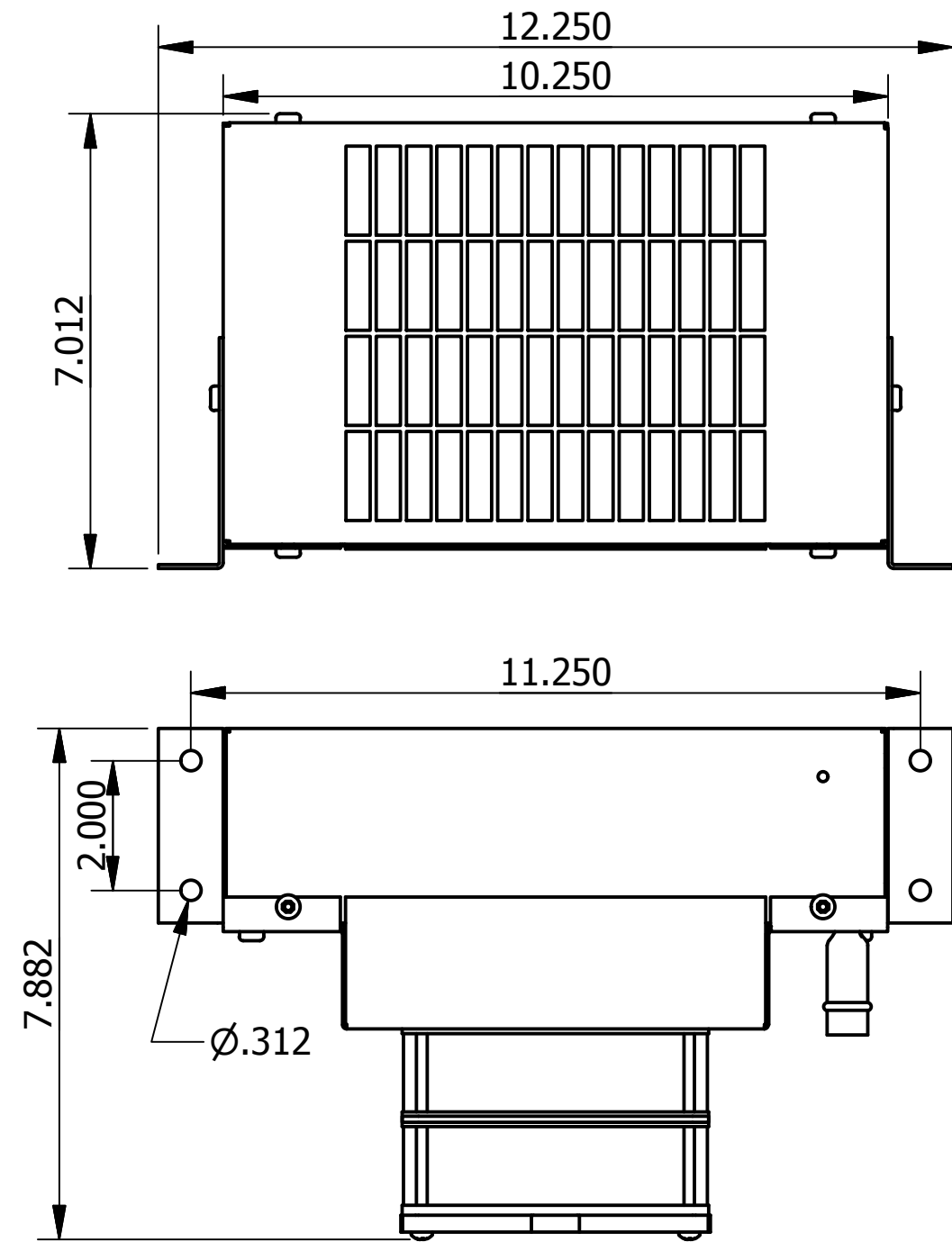

PROPRIETARY & CONFIDENTIAL. UNPUBLISHED WORK COPYRIGHT PRO AIR LLC. PRO AIR, LLC CLAIMS PROPRIETARY RIGHTS IN THE MATERIAL DISCLOSED HEREON. NEITHER THIS DRAWING NOR ANY REPRODUCTION OR PORTION THEREOF MAY BE DISTRIBUTED OR USED TO MANUFACTURE ANYTHING SHOWN HEREON WITHOUT PERMISSION IN WRITING FROM PROAIR, LLC.

REV. A

|      |     |          |  |                        |      |             |  |        |  |  |  |                       |  |                     |        |
|------|-----|----------|--|------------------------|------|-------------|--|--------|--|--|--|-----------------------|--|---------------------|--------|
| A    |     | 18-001   |  | RELEASED TO PRODUCTION |      | CEB         |  | 1/3/18 |  | <br>2900 COUNTY RD 6 W ELKHART, IN 46514 |  | TITLE:                |  | PART NO. 66 000 504 |        |
| LET. | NO. | REVISION |  | BY                     | DATE | SIGNATURES  |  | DATE   |  |  |  | HEATER, 423 120mm FAN |  | SCALE: .375 : 1     | SIZE A |
|      |     |          |  |                        |      | DRAWN CEB   |  | 1/3/18 |  | USAGE:                                   |  | 423                   |  | SHEET 1 OF 1        |        |
|      |     |          |  |                        |      | CHECKED RAI |  | 1/3/18 |  |  |  |                       |  |                     |        |
|      |     |          |  |                        |      | APPROVED    |  |        |  |  |  |                       |  |                     |        |